

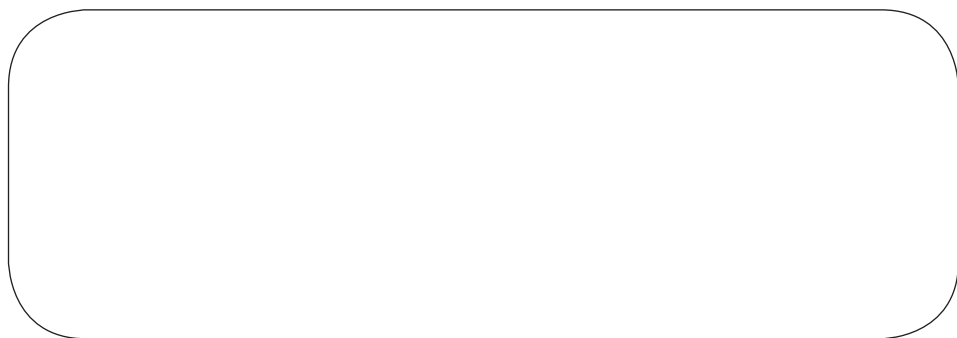

# **BUILT-IN GAS OVENS**



Instructions for the use - Installation advices  
**KEEP IN A SAFE PLACE**

Before operating this oven,  
please read these instructions carefully



**Dear Customer,**

*Thank you for having purchased and given your preference to our product. The safety precautions and recommendations within this booklet are for your own safety and that of others. They will also provide a means by which to make full use of the features offered by your appliance.*

*Please preserve this booklet carefully. It may be useful in future, either to yourself or to others in the event that doubts should arise relating to its operation.*

***This appliance must be used only for the task it has explicitly been designed for, that is for cooking foodstuffs. Any other form of usage is to be considered as inappropriate and therefore dangerous.***

***The manufacturer declines all responsibility in the event of damage caused by improper, incorrect or illogical use of the appliance.***

## IMPORTANT SAFETY PRECAUTIONS AND RECOMMENDATIONS

**IMPORTANT:** This appliance is designed and manufactured solely for the cooking of domestic (household) food and is not suitable for any non domestic application and therefore should not be used in a commercial environment.

The appliance guarantee will be void if the appliance is used within a non domestic environment i.e. a semi commercial, commercial or communal environment.

**Read the instructions carefully before installing and using the appliance.**

- This appliance has been designed and manufactured in compliance with the applicable standards for the household cooking products, including those for surface temperatures. Some people with sensitive skin may have a more pronounced temperature perception with some components although these parts are within the limits allowed by the norms. The complete safety of the appliance also depends on the correct use, we therefore recommend to always pay a extreme attention while using the product, especially in the presence of children.
- After having unpacked the appliance, check to ensure that it is not damaged and that the oven door closes correctly. In case of doubt, do not use it and consult your supplier or a professionally qualified technician.
- Packing elements (i.e. plastic bags, polystyrene foam, nails, packing straps, etc.) should not be left around within easy reach of children, as these may cause serious injuries.
- Some appliances are supplied with a protective film on steel and aluminium parts. **This film must be removed before using the appliance.**
- **IMPORTANT:** The use of suitable protective clothing/gloves is recommended when handling or cleaning this appliance.
- Do not attempt to modify the technical characteristics of the appliance as this may become dangerous to use. The

manufacturer declines all responsibility for any inconvenience resulting from the inobservance of this condition.

- CAUTION: this appliance must only be installed in a permanently ventilated room in compliance with the applicable regulations.
- Do not operate your appliance by means of an external timer or separate remote-control system.
- Do not carry out cleaning or maintenance operations on the appliance without having previously disconnected it from the electric power supply.
- WARNING: Ensure that the appliance is switched off before replacing the oven lamp to avoid the possibility of electric shock.
- Do not use a steam cleaner because the moisture can get into the appliance therefore making it unsafe.
- Do not touch the appliance with wet or damp hands (or feet).
- Do not use the appliance whilst in bare feet.
- If you should decide not to use this appliance any longer (or decide to substitute another model), before disposing of it, it is recommended that it be made inoperative in an appropriate manner in accordance to health and environmental protection regulations, ensuring in particular that all potentially hazardous parts be made harmless, especially in relation to children who could play with unused appliances.
- The various components of the appliance are recyclable. Dispose of them in accordance with the regulations in force in your country. If the appliance is to be scrapped, remove the power cord.
- After use, ensure that the knobs are in the off position.
- Children less than 8 years of age shall be kept away unless continuously supervised.
- This appliance can be used by children aged from 8 years and above and persons with reduced physical, sensory or mental capabilities or lack of experience and knowledge if they have been given supervision or instruction concerning use of the appliance in a safe way and understand the hazards involved. Children shall not play with the appliance. Cleaning and user maintenance shall not be made by children without supervision.

- The manufacturer declines all liability for injury to persons or damage to property caused by incorrect or improper use of the appliance.
- **WARNING:** During use the appliance and its accessible parts become hot; they remain hot for some time after use.
  - Care should be taken to avoid touching heating elements inside the oven.
  - The door is hot, use the handle.
  - To avoid burns and scalds, young children should be kept away.
- Make sure that electrical cables connecting other appliances in the proximity of the oven cannot become entrapped in the oven door.
- **WARNING:** When correctly installed, your product meets all safety requirements laid down for this type of product category. However special care should be taken around the rear or the underneath of the appliance as these areas are not designed or intended to be touched and may contain sharp or rough edges, that may cause injury.
- **FIRST USE OF THE OVEN** - it is advised to follow these instructions:
  - Furnish the interior of the oven as described in the chapter “CLEANING AND MAINTENANCE”.
  - Switch on the empty oven on max to eliminate grease from the heating elements.
  - Disconnect the appliance from the electrical power supply, let the oven cool down and clean the interior of the oven with a cloth soaked in water and neutral detergent; then dry carefully.
- **CAUTION:** Do not use harsh abrasive cleaners or sharp metal scrapers to clean the oven door glass since they can scratch the surface, which may result in shattering of the glass.
- Do not line the oven walls or floor with aluminium foil. Do not place baking trays or the drip tray on the base of the oven chamber.
- **FIRE RISK!** Do not store flammable material in the oven.

- Always use oven gloves when removing the shelves and food trays from the oven whilst hot.
- Do not hang towels, dishcloths or other items on the appliance or its handle – as this could be a fire hazard.
- Clean the oven regularly and do not allow fat or oils to build up in the oven base or tray. Remove spillages as soon as they occur.
- Do not stand on the open oven door.
- Always stand back from the appliance when opening the oven door to allow steam and hot air to escape before removing the food.
- **SAFE FOOD HANDLING:** Leave food in the oven for as short a time as possible before and after cooking. This is to avoid contamination by organisms which may cause food poisoning. Take particular care during warmer weather.
- **WARNING:** Take care NOT to lift the appliance by the door handle.
- The appliance must not be installed behind a decorative door in order to avoid overheating.
- The oven accessories (e.g. oven wire rack) must be fitted correctly as indicated at page 24.
- If the power supply cable is damaged, it must be replaced only by an authorized service agent in order to avoid a hazard.

# 1 CONTROL PANELS

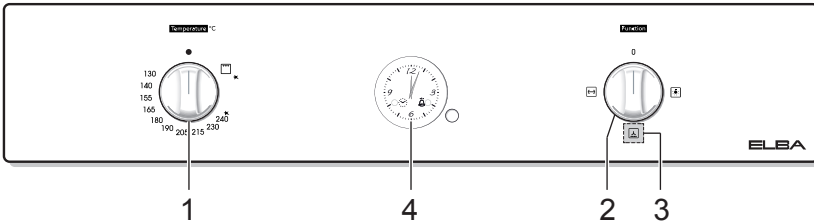

Fig. 1.1

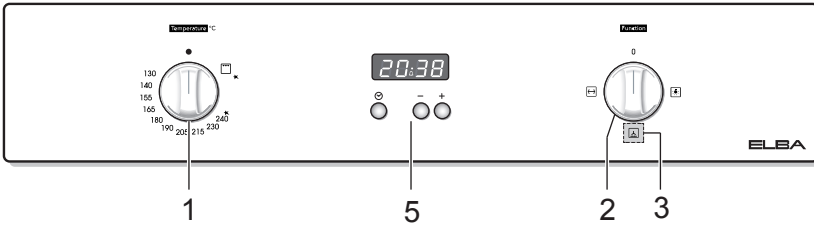

Fig. 1.2

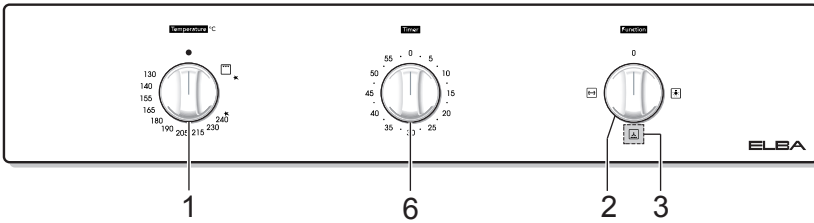

Fig. 1.3

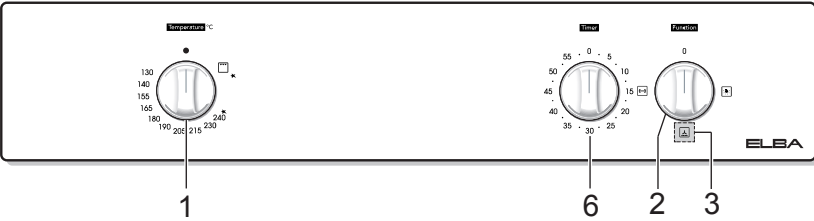

Fig. 1.4

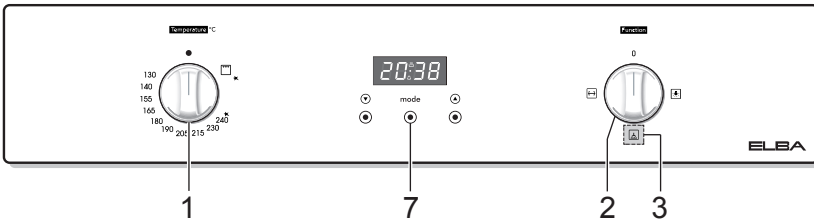



Fig. 1.5

## CONTROLS DESCRIPTION

1. Gas oven/grill thermostat control knob
2. Oven light/roastisserie control knob
3. If the product is a “fan assisted” gas oven, the oven light/roastisserie control knob has also the position  (fan motor)
4. Electric clock with alarm
5. Electronic clock with alarm
6. 60' or 120' alarm control knob
7. Digital electronic clock with timer (with “Touch-control” keys)

### Notes:

- The electric ignition is incorporated in the thermostat control knob.
- The appliance has a safety valve system fitted, the flow of gas will be stopped if and when the flame should accidentally go out.

### CAUTION:

If the burner is accidentally extinguished, turn the gas off at the control knob and wait at least 1 minute before attempting to relight.

### CAUTION:

Gas appliances produce heat and humidity in the environment in which they are installed.

Ensure that the cooking area is well ventilated by opening the natural ventilation grilles or by installing an extractor hood connected to an outlet duct.

### CAUTION:

If the appliance is used for a prolonged time it may be necessary to provide further ventilation by opening a window or by increasing the suction power of the extractor hood (if fitted).

### NOTES:

**The knobs and symbols may vary.  
The symbols may be printed on the knob itself.**

# 2

## HOW TO USE THE OVEN

### ATTENTION:

The oven door becomes very hot during operation and very hot steam goes out from the area below the control panel. Keep children away.

The door is hot, use the handle.

During use the appliance becomes hot. Care should be taken to avoid touching the heating elements inside the oven.

### TECHNICAL FEATURES

The oven is furnished completely clean.

It is advisable however, upon first use, to turn the oven on to the maximum temperature to eliminate possible traces of grease from the oven burner.

The same operation shall be done with the gas grill.

This oven is fitted with:

- One gas oven burner (2,70 kW), located at the bottom, providing self-ignition and safety device.
- One gas grill burner (1,70 kW), placed on the top, providing self-ignition and safety device.
- **Only for the “fan assisted” models (models having also the position  fan motor, on the oven light/roast control knob)** - A fan motor, positioned on the back panel of the oven cavity, which can be used in combination with the oven gas burner or alone, without heating.

**IMPORTANT NOTE - It is not possible to use the fan motor in combination with the gas grill: a safety device switches off the fan motor when the gas oven/grill control knob is turned on grill position.**

### OPERATING PRINCIPLES

Heating and cooking in the gas oven are obtained in the following ways:

#### a. by normal convection

The heat is produced by the oven gas burner.

#### b. by forced convection (only for the “fan assisted” models - models having also the position , fan motor, on the oven light/roast control knob)

The heat produced by the oven burner is distributed throughout the oven by the fan.

#### c. by radiation

The heat is radiated by the gas grill.

#### d. by ventilation (only for the “fan assisted” models - models having also the position , fan motor, on the oven light/roast control knob)

The food is defrosted by using the fan only without oven burner (this is not a cooking function).

### COOLING FAN MOTOR

This appliance incorporates a safety cooling fan motor to achieve optimum efficiency of the controls, ensure lower surface temperatures are maintained and cool the internal components.

The cooling fan motor turns on automatically when igniting the oven or grill burner.

It may run on (for various minutes) even after the oven or grill burner has been turned off.

## IMPORTANT NOTES:

- Do not use the appliance in case of power failure or if the cooling fan motor is damaged. The appliance may overheat and get damaged due to the non-operation of the cooling fan motor.
- In case of failure of the cooling fan motor during the operation of the gas oven or gas grill, the oven or grill burner is turned off automatically after about 20 minutes. In that case do not use the oven or the grill and contact the after-sales service.
- When the cooling fan motor is operating correctly there is an air flow in the top area of the appliance.

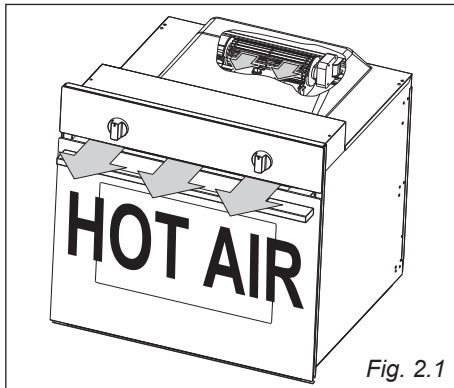

Fig. 2.1

## OVEN BURNER

The gas flow to the burner is regulated by a thermostat which allow to maintain the oven temperature constant.

The control of the temperature is assured by a thermostatic probe positioned inside the oven.

The probe must be always kept in its housing, in a clean condition, as an incorrect position or encrustment may cause an alteration in the control of the temperature.

Moreover, the thermostat is fitted with a safety valve which automatically shuts off the gas supply when the flame goes out.

## THERMOSTAT

The numbers printed on the control panel or on the knob (fig. 2.2) indicate the increasing oven temperature value (see table below).

To regulate the temperature, set the knob to the chosen number. The "FAN ASSISTED GAS OVEN" column refers to the oven burner used in combination with the fan motor (forced convection cooking: only for the "fan assisted" models - models having also the position , fan motor, on the oven light/roisserie control knob), while the "GAS OVEN" column refers to the oven burner used in the normal convection mode (without fan motor). The ★ symbol close to the maximum position indicates that the electric ignition is incorporated into the knob (activated by the knob itself).

NOTES: The knob and symbols may vary. The symbols may be printed on the knob itself.

Temperature °C

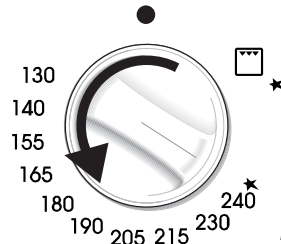

Fig. 2.2

### THERMOSTAT GRADE TABLE (°C)

Knob position	GAS OVEN	FAN ASSISTED GAS OVEN
130 (or 1)	130	130
140 (or 2)	140	140
155 (or 3)	155	155
165 (or 4)	165	165
180 (or 5)	180	180
190 (or 6)	190	190
205 (or 7)	205	205
215 (or 8)	215	215
230 (or 9)	230	230
240 (or 10)	240	240

## LIGHTING OF OVEN BURNER

**IMPORTANT:** The oven door must be open during this operation.

To light the oven burner:

- 1 – Open the oven door to the full extent.



**If this operation is not performed you should not proceed to light the oven.**

- 2 – Lightly press and turn the thermostat knob anti-clockwise to the maximum position  (fig. 2.2). Press the knob firmly until the burner lights.

**Never continue this operation for more than 15 seconds. If the burner has still not ignited, wait for about 1 minute prior to repeating the ignition.**

In case of mains failure, approach a lighted match or taper to the opening “A” (fig. 2.3) and immediately press the knob firmly.

- 3 – Wait about 10/15 seconds after the burner lighting before releasing the knob (time of priming of the valve).
- 4 – Check that the burner has lit; if not, turn the knob clockwise back to “0”, “●” or “○” (OFF) and repeat the procedure from step 1.
- 5 – Close the oven door slowly and adjust the burner according to the power required.

If the flame extinguishes for any reason, the safety valve will automatically shut off the gas supply to the burner.

To re-light the burner, first turn the oven control knob to OFF position (“0”, “●” or “○”), **wait for at least 1 minute** and then repeat the lighting procedure.

For the correct use of the gas oven see the chapters “COOKING WITH GAS OVEN” and “COOKING WITH FAN ASSISTED GAS OVEN” (only for the “fan assisted” models - models having also the position , fan motor, on the oven light/roastisserie control knob).

During and after use of the oven, certain parts will become very hot. Keep children away.

**ATTENTION:** In case of manual lighting, never turn the thermostat before approaching a flame to the hole “A” of the floor.

For correct use of the gas oven, always preheat it (bottom burner) for at least 15 minutes.

Preheating should always be carried out with the oven empty: remove the trays and racks from the oven cavity.

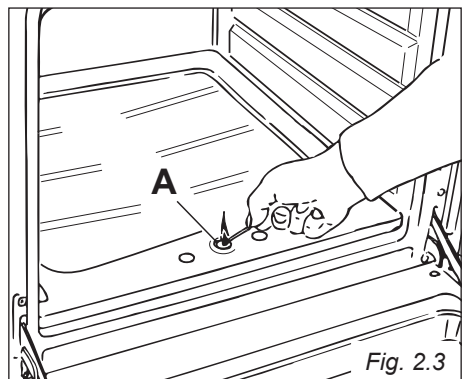

Fig. 2.3

## LIGHTING OF GAS GRILL BURNER

**IMPORTANT:** The oven door must be open during this operation.

To light the grill burner:

- 1 – Open the oven door to the full extent.



If this operation is not performed you should not proceed to light the grill.

- 2 – Lightly press and turn the thermostat knob clockwise to the position  (fig. 2.4). Press the knob firmly until the burner lights.

**Never continue this operation for more than 15 seconds. If the burner has still not ignited, wait for about 1 minute prior to repeating the ignition.**

In case of mains failure, approach a lighted match or taper to the pipe of the burner (fig. 2.5) and immediately press the knob firmly.

- 3 – Wait about 10/15 seconds after the burner lighting before releasing the knob (time of priming of the valve).
- 4 – Check the grill burner has lit; if not, turn the knob counter-clockwise back to “0”, “●” or “○” (OFF) and repeat the procedure from step 1.
- 5 – Close the oven door slowly.

**The grill must always be used with the oven door closed.**

For correct use see chapter “USE OF THE GRILL”.

If the flame extinguishes for any reason, the safety valve will automatically shut off the gas supply to the burner.

To re-light the burner, first turn the oven control knob to OFF position (“0”, “●” or “○”), wait for at least 1 minute and then repeat the lighting procedure.

**IMPORTANT NOTE (only for the “fan assisted” models - models having also the position , fan motor, on the oven light/rotisserie control knob):** It

is not possible to use the fan motor in combination with the gas grill; a safety device switches off the fan motor when the gas oven/grill control knob is turned on grill position.

**ATTENTION:** The oven door becomes very hot during operation. Keep children away.

**During and after use of the grill, certain parts will become very hot. Keep children away.**

**ATTENTION:** In case of manual lighting, never turn the thermostat before approaching a flame to the burner.

**NOTES:** The knob and symbols may vary. The symbols may be printed on the knob itself.

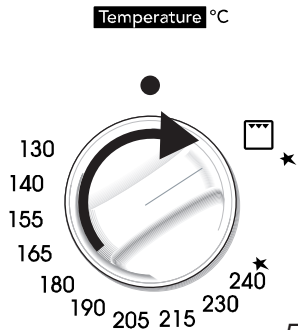

Fig. 2.4

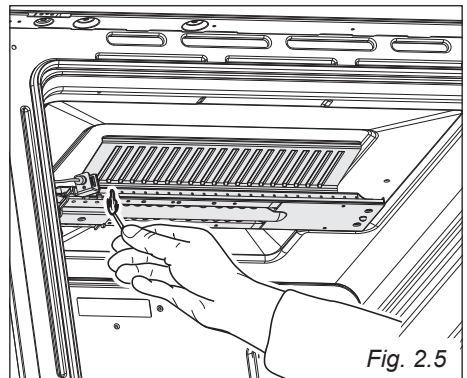

Fig. 2.5

## COOKING WITH GAS OVEN

Before introducing the food, preheat the oven to the desired temperature.

For a correct preheating operation, it is advisable to remove the tray from the oven and introduce it together with the food, when the oven has reached the desired temperature.

Check the cooking time and turn off the oven 5 minutes before the theoretical time to recuperate the stored heat.

### FAN MOTOR (Only for the “fan assisted” models - models having also the position , fan motor, on the oven light/roisserie control knob)

The fan motor is designed to distribute throughout the oven the heat generated by the oven gas burner.

The fan motor can also be used without the oven gas burner (without heating) to defrost frozen foods.

The fan is controlled by a knob (fig. 2.6).

- To operate the fan motor turn the knob indicated in fig. 2.6 to  position.
- To switch it off turn the knob to the off position (“O” or “0”).

**IMPORTANT:** When using the fan motor together with the oven gas burner, switch on the fan only after the ignition of the gas burner.

### COOKING WITH FAN ASSISTED GAS OVEN (Only for the “fan assisted” models - models having also the position , fan motor, on the oven light/roisserie control knob) OVEN BURNER AND FAN MOTOR

After the ignition of the gas burner, close the oven door and switch on the fan motor. Before introducing the food, preheat the oven to the desired temperature.

For a correct preheating operation, it is

advisable to remove the tray from the oven and introduce it together with the food, when the oven has reached the desired temperature.

Check the cooking time and turn off the oven 5 minutes before the theoretical time to recuperate the stored heat.

Only for the “fan assisted” models - models having also the position , fan motor, on the oven light/roisserie control knob.

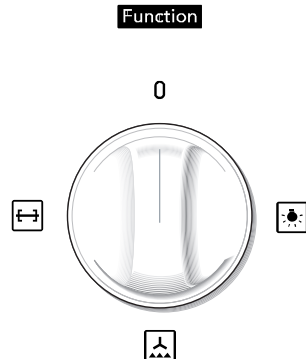

Fig. 2.6

**NOTES:** The knob and symbols may vary. The symbols may be printed on the knob itself.

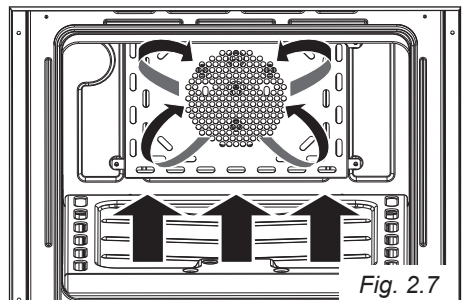



Fig. 2.7

## DEFROSTING FROZEN FOODS

(Only for the “fan assisted” models - models having also the position , fan motor, on the oven light/roastisserie control knob)

### FAN MOTOR ONLY

Switch on the fan motor only.

The oven thermostat control knob shall be in the “0”, “●” or “O” (OFF) position.

The defrosting is done by simple ventilation without heat.

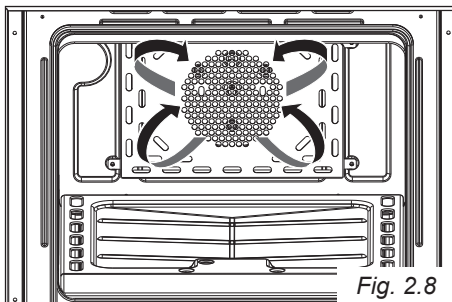

## USE OF THE GRILL

**Very important: The grill must always be used with the oven door closed.**

Turn on the grill, as explained in the preceding paragraphs and let the oven preheat for about 5 minutes with the door closed.

Introduce the food to be cooked, positioning the rack as close to the grill as possible.

The dripping pan should be placed under the rack to catch the cooking juices and fats.

**Note: It is recommended that you do not grill for longer than 30 minutes at any one time.**

**Attention: The oven door becomes very hot during operation. Keep children away.**

## OVEN LIGHT

The oven provides an interior lamp to allow the visual inspection during the cooking.

To light the oven lamp turn the knob (fig. 2.6 or 2.9) to the symbol .

## ROTISSERIE

The oven is fitted with a rotisserie.

To operate the rotisserie motor turn the knob indicated in fig. 2.6 or 2.9 to  position.

For the correct use see specific instructions in the section “USING THE ROTISSERIE”.

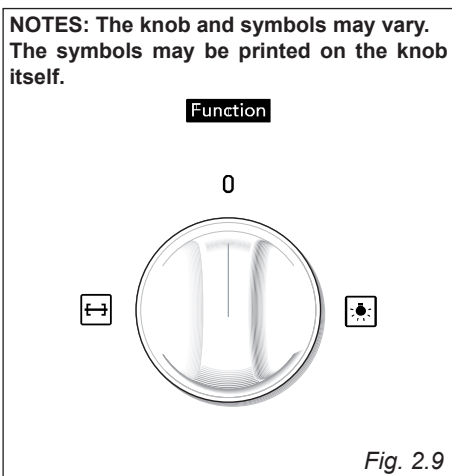

**USING THE ROTISSERIE (Models without fan assisted oven - Without fan motor) - figs. 2.10a, 2.10b or 2.11**

**Very important: The rotisserie must always be used with the oven door closed.**

- Insert the dripping pan into the lowest level of the oven and insert the rod support into the intermediate level.
- Put the meat to be cooked onto the rod, being careful to secure it in the center with the special forks.
- Insert the skewer into the motor hole and rest the collar on the support; remove the handgrip by turning it to the left.
- Light the grill burner and then switch on the rotisserie.  
The rotation direction of the rotisserie can be either clockwise or counterclockwise.

**USING THE ROTISSERIE (Only for the “fan assisted” models - models having also the position , fan motor, on the oven light/rotisserie control knob) - fig. 2.12**

**Very important: The rotisserie must always be used with the oven door closed.**

- Insert the dripping pan into the lowest rack holders of the oven and insert the rod support into the intermediate rack holders.
- Put the meat to be cooked onto the rod, being careful to secure it in the center with the special forks.
- Insert the rod into the side gear opening “R” (fig. 2.12).
- Remove the handgrip by turning it to the left.
- Insert completely the rotisserie support; the shaft “P” must be inserted in the spit motor collar “F”.
- Light the grill burner and then switch on the rotisserie.  
The rotation direction of the rotisserie can be either clockwise or counterclockwise.

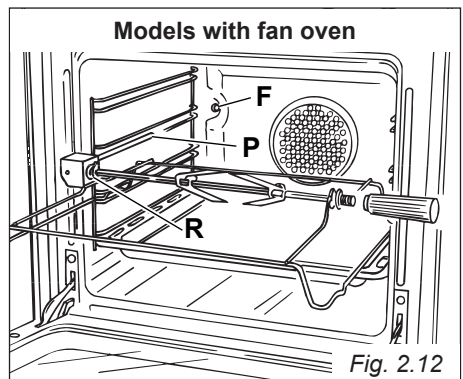
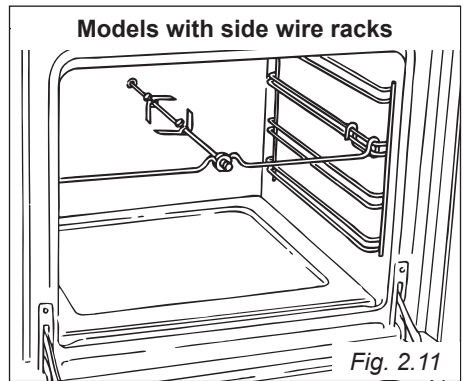
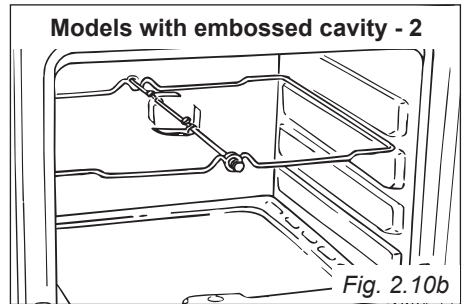
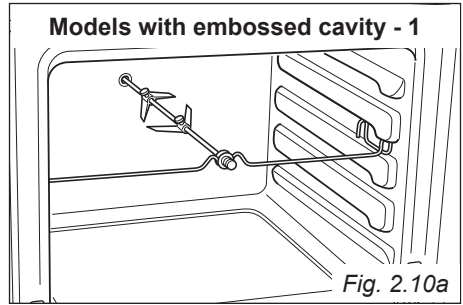

# 3

## ALARM, ELECTRIC OR ELECTRONIC CLOCK

### 60' ALARM (fig. 3.1)

The timer is equipped with a time buzzer and may be regulated for a maximum period of 60 minutes.

The regulating knob must be turned in a clockwise direction until it reaches the 60 minutes position and then turned to the desired time by turning the knob in a counterclockwise direction.

### 120' ALARM (fig. 3.2)

The timer is equipped with a time buzzer and may be regulated for a maximum period of 120 minutes.

The regulating knob must be turned in a clockwise direction until it reaches the 120 minutes position and then turned to the desired time by turning the knob in a counterclockwise direction.

#### ATTENTION - MOST IMPORTANT:

This is only a mechanical timer that DOES NOT switch off the oven or grill.

REMEMBER TO TURN OFF THE OVEN OR GRILL MANUALLY.

NOTES: The knob and symbols may vary.  
The symbols may be printed on the knob itself.

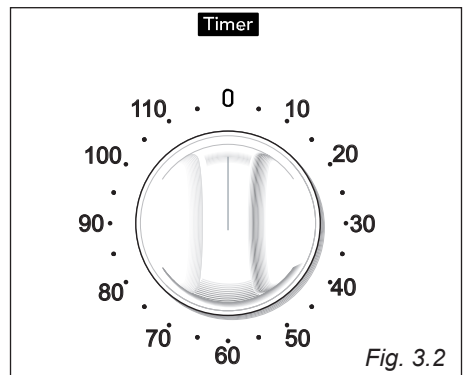
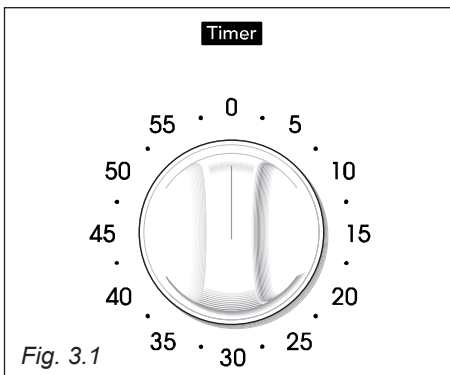

## MODELS WITH ELECTRIC CLOCK WITH MINUTE MINDER (fig. 3.3)

The electric clock is a device which groups the following functions:

- 12-hour analog clock;
- minute minder (max 3 hours);
- acoustic signal (beep) which is activated each time the “setting knob” is pressed or at the end of the minute minder function.

### ELECTRIC CLOCK

Upon immediate connection of the oven or after a blackout, the “clock indicator light” is flashing. This indicates that it is recommended to check if the time of the day is correct.

- If the time of the day is correct keep the “setting knob” pressed until the “clock indicator light” goes out.
- To set the time of the day press the “setting knob” briefly (repeatedly) until the “clock indicator light” is flashing. Then turn the “setting knob” (to the right or left) to set the time of the day. At the end of the time adjustment, keep the “setting knob” pressed for confirmation until the “clock indicator light” goes out.

### MINUTE MINDER

The minute minder function consists only of a buzzer which is automatically activated at the end of the set time (max 3 hours).

To set the minute minder press the “setting knob” briefly (one or more times) until the “minute minder indicator light” is flashing.

Then turn the “setting knob” (to the right or left) to set the time.

At the end of the adjustment (within 10 seconds), keep the “setting knob” pressed for confirmation until the “minute minder indicator light” changes from flashing to steadily lit.

Then the countdown starts immediately.

At the end of the time, the “minute minder indicator light” changes from steadily lit to flashing and a buzzer (beep) sounds for one minute.

Press the “setting knob” briefly to stop the buzzer and to turn off the flashing “minute minder indicator light”.

During the minute minder program it is possible, at any time, to display the set time by pressing the “setting knob” briefly (one or more times) until the “minute minder indicator light” is flashing.

To cancel the program before completion, keep the “setting knob” pressed for about 3 seconds; the minute minder function will be cancelled.

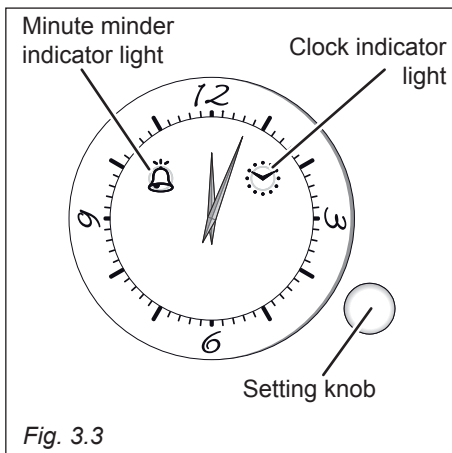

**ATTENTION - MOST IMPORTANT:**  
**This is only an alarm that DOES NOT switch off the oven or grill.**  
**REMEMBER TO TURN OFF THE OVEN OR GRILL MANUALLY.**



## ELECTRONIC CLOCK WITH ALARM

(fig. 3.4)

The electronic clock is a device which groups the following functions:

- 24 hours clock with illuminated display;
- 99 minutes alarm.





Upon immediate connection of the oven or after a blackout, three zeros will flash on the display.



To set the hour it is necessary to push the  button and then, within 7 seconds, the  or  button until you have set the exact hour.







**An energy black-out makes the clock go to zero.**

## ELECTRONIC ALARM

The alarm program consists only of a buzzer which may be set for a maximum period of 99 minutes.

To set the time, push the  () or  () button until you obtain the desired time in the display. Having finished the setting, the  symbol will be lighted and the countdown will start immediately.



At the end of the time, an intermittent buzzer, during 7 minutes, will go off; this can be stopped by pressing the  () button.

To stop the alarm countdown in any moment press the  () and  () buttons together and release the  () button first.

### ATTENTION - MOST IMPORTANT:

**This is only an electronic alarm that DOES NOT switch off the oven or grill. REMEMBER TO TURN OFF THE OVEN OR GRILL MANUALLY.**



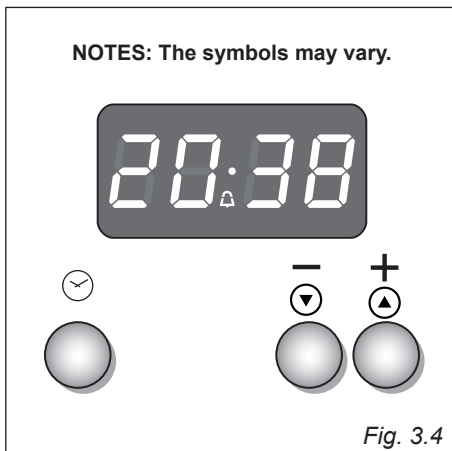

## SETTING THE FREQUENCY OF THE ALARM SOUND

The selection from 3 possibilities of sound can be made by pressing the  () button.





## DIGITAL ELECTRONIC CLOCK WITH TIMER (fig. 3.5)

### CLOCK and TIMER with “ TOUCH CONTROL ” KEYS

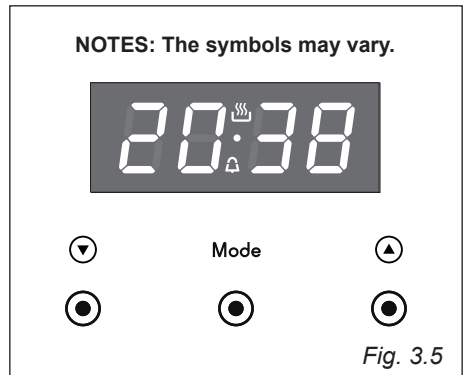
Keys:	
 and 	<p>T o u c h e d simultaneously (for more than 2 seconds):</p> <ul style="list-style-type: none"> <li>• setting the clock;</li> <li>• setting the timer volume (by touching once, along with the “<b>MODE</b>” key).</li> </ul>
“ <b>MODE</b> ”	<p>Function selection (touched for more than 2 seconds):</p> <ul style="list-style-type: none"> <li>• setting the clock (only after first connection or after a power failure);</li> <li>• timer.</li> </ul>
	Increases the number shown on the display
	Decreases the number shown on the display





Illuminated symbols:		
	<b>flashing</b>	Timer being set
	<b>steady illumination</b>	Timer in operation

**ATTENTION - MOST IMPORTANT:**  
**This is only an alarm that DOES NOT switch off the oven or grill.**  
**REMEMBER TO TURN OFF THE OVEN OR GRILL MANUALLY.**

### “TOUCH-CONTROL” KEYS



The “touch-control” keys shall be operated by the fingers (just by touching the key). When using touch controls it is best to use the ball of your finger rather than the tip. The keys are automatically deactivated:





- 8 seconds after the last selection; the deactivation is indicated by an acoustic signal (“beep”).

To reactivate just touch the “ **MODE** ” key or the “  ” and “  ” keys (simultaneously) for more than 2 seconds.

## SETTING THE CLOCK

When first connected, or after a power failure, the digits will flash on the display.

To set the clock, touch the “ **MODE** ” key, for more than 2 seconds, and then the “  ” or “  ” keys.







To set the clock, with the appliance already connected, touch the “  ” and “  ” keys simultaneously (for more than 2 seconds), then “  ” or “  ” keys.

## USING THE TIMER

You can use the timer at any time, even when the oven is not in use.



The timer does not turn the oven off.

The timer can be set for up to 23 hours and 59 minutes.

- To set the timer, touch the “ **MODE** ” key for more than 2 seconds (the “  ” symbol flashes), then the “  ” or “  ” keys.
- After about 8 seconds an acoustic signal (“**beep**”) will sound confirming the regulation (“  ” symbol steady illuminated).
- To check the remaining time touch the “ **MODE** ” key for more than 2 seconds. If the remaining time is more than a minute the display will show hours and minutes; if less than a minute the display will show seconds.
- When the time is up, the timer will beep. Touch the “ **MODE** ” key , for more then 2 seconds, to turn it off; or press the “  ” or “  ” key to stop the beep and than the “ **MODE** ” key, for more than 2 seconds, to deactivate the “  ” symbol flashing on the display.
- Turn off the oven manually (thermostat knob in the off position) if the cooking has been completed.

## SETTING THE TIMER VOLUME

You can select from three volume levels.

- Touch the “  ” and “  ” keys simultaneously for more than 2 seconds.
- Touch the “ **MODE** ” key; you can read on the display the current timer volume (“**ton1**”, “**ton2**” or “**ton3**”).
- Touch the “  ” key to listen or change the timer volume.
- Timer volume activated: the last displayed.
- After about 8 seconds an acoustic signal (“**beep**”) will sound confirming the volume setting; then the time of day will be displayed.

# 4

## CLEANING AND MAINTENANCE

### GENERAL ADVICE

#### Important:

**Before any operation of cleaning and maintenance disconnect the appliance from the electrical supply.**

- It is advisable to clean when the appliance is cold and especially for cleaning the enamelled parts.
- Avoid leaving alkaline or acidic substances (lemon juice, vinegar, etc.) on the surfaces.
- Do not use cleaning products with a chlorine or acidic base.
- The oven must always be cleaned after every use, using suitable products.

### WARNING

**When correctly installed, your product meets all safety requirements laid down for this type of product category. However special care should be taken around the rear or the underneath of the appliance as these areas are not designed or intended to be touched and may contain sharp or rough edges, that may cause injury.**

### INSIDE OF OVEN

The oven should always be cleaned after use when it has cooled down.

The cavity should be cleaned using a mild detergent solution and warm water.

Suitable proprietary chemical cleaners may be used after first consulting with the manufacturers recommendations and testing a small sample of the oven cavity.

Abrasive cleaning agents or scouring pads/cloths should not be used on the cavity surface.

**NOTE:** The manufacturers of this appliance will accept no responsibility for damage caused by chemical or abrasive cleaning.

**Let the oven cool down and pay special attention no to touch the hot heating elements inside the oven cavity.**

### REMOVABLE INNER DOOR PANE (only for the models with removable inner pane of glass)

Follow the instructions of pages 26, 27, 28, 29.

**Do not use a steam cleaner because the moisture can get into the appliance thus make it unsafe.**

**Do not store flammable material in the oven.**

## **ENAMELLED PARTS**

All the enamelled parts must be cleaned with a sponge and soapy water or other non-abrasive products.

Dry preferably with a microfibre or soft cloth.

Acidic substances like lemon juice, tomato sauce, vinegar etc. can damage the enamel if left too long.

## **GLASS CONTROL PANEL (MODELS WITH GLASS CONTROL PANEL)**

Clean using an appropriate product.

Always dry thoroughly.

Do not use harsh abrasive cleaners or sharp metal scrapers to clean the control panel since they can scratch the surface, which may result in shattering of the glass.

## **STAINLESS STEEL SURFACES (MODELS WITHOUT ANTI-FINGERPRINT TREATMENT), ALUMINIUM PARTS AND PAINTED OR SILK-SCREEN PRINTED SURFACES**

Clean using an appropriate product. Always dry thoroughly.

**IMPORTANT:** these parts must be cleaned very carefully to avoid scratching and abrasion.

You are advised to use a soft cloth and neutral soap.

## **STAINLESS STEEL SURFACES WITH ANTI-FINGERPRINT TREATMENT (SOME MODELS ONLY)**

**CAUTION:** The stainless steel front surfaces used in some ovens are protected with a Special Lacquer to reduce fingerprint marks.

To avoid damaging this lacquer, do not clean the stainless steel with abrasive cleaners or abrasive cloths or scouring pads.

**ONLY SOAP/WARM WATER MUST BE USED TO CLEAN THE STAINLESS STEEL SURFACES.**

**Do not use harsh abrasive cleaners or sharp metal scrapers to clean the oven door glass since they can scratch the surface, which may result in shattering of the glass.**

## OVEN FITTING OUT

### MODELS WITH EMBOSSED CAVITY

The oven shelf must be inserted operating as per figure 4.1a.

To pull it out operate in the inverse order.

**Some model only:** The oven shelf is provided with a security block to prevent accidental extraction. It must be inserted operating as per figure 4.1b.

To pull it out operate in the inverse order.

**Oven tray:** Insert the dripping pan into the side guides of the oven cavity operating as indicated for the standard shelf (without security block, fig. 4.1a).

To pull it out operate in the inverse order.

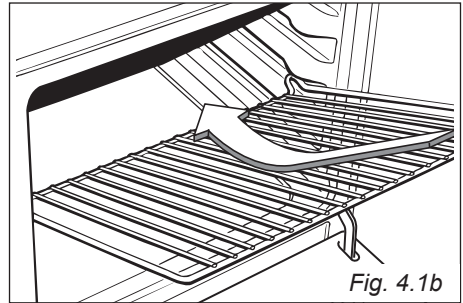
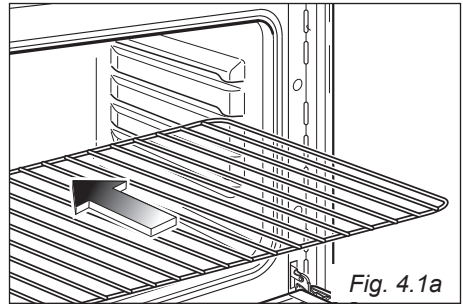

### MODELS WITH WIRE RACKS

- Hang up the wire racks "G" on the oven walls (fig. 4.2).

**In the models with catalytic panels supplied:** interpose the catalytic panels "A" (fig. 4.2).

- Slide in, on the guides, the shelf and the tray (fig. 4.3).  
The shelf must be fitted so that the safety catch, which stops it sliding out, faces the inside of the oven.
- To dismantle, operate in reverse order.

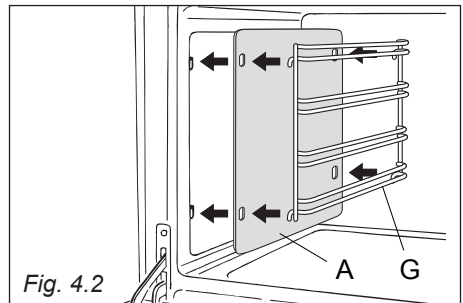

### ADVICE FOR USE AND MAINTENANCE OF CATALYTIC PANELS (SOME MODELS ONLY)

The self-cleaning panels are coated in a special microporous enamel which absorbs and automatically eliminates spatters of oil and grease during normal cooking above 200°C.

If, after cooking very greasy foods, the panels are still dirty, run the oven empty at maximum temperature for approximately 30 minutes.

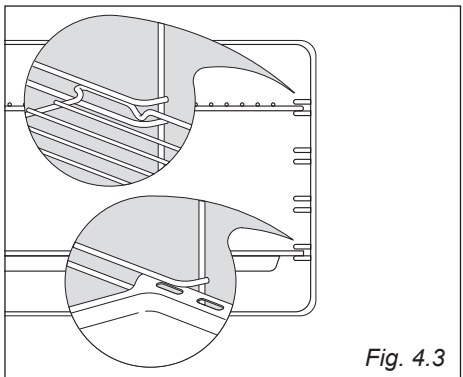

These panels do not require cleaning but periodically it is nevertheless a good idea to take them out and dust with a soft damp cloth.

**Do not wash or clean with abrasive products or products containing acids or alkalis.**

The side panels are reversible and can be turned round and fitted on the other side when the microporous enamel is worn.

### GREASE FILTER - FAN ASSISTED OVENS (SOME MODELS ONLY)

- A special screen is provided at the back of the oven to catch grease particles, mainly when meat is being roasted (fig. 4.4).
- When baking pastry etc. this filter should be removed.
- Slide in the grease filter on the back of the oven as in fig. 4.4.
- **Clean the filter after any cooking!**  
The grease filter can be removed for cleaning and should be washed regularly in hot soapy water. Always clean the filter after cooking as any solid residues on it might adversely affect the oven performance.
- Always dry the filter properly before fitting it back into the oven.

### REPLACING THE OVEN LAMP

**WARNING:** Ensure the appliance is switched off and disconnected from the electrical power supply before replacing the lamp to avoid the possibility of electric shock.

- Let the oven cavity and the heating elements to cool down.
- Switch off the electrical supply.
- Remove the protective cover "A" (fig. 4.5).

- Replace the halogen lamp "C" with a new one suitable for high temperatures (300°C) having the following specifications: 220-240V, 50/60Hz and same power (check watt power as stamped in the lamp itself) of the replaced lamp.

**IMPORTANT WARNING:** Never replace the bulb with bare hands; contamination from your fingers can cause premature failure. Always use a clean cloth or gloves.

- Refit the protective cover.

**Note:** Oven lamp replacement is not covered by your guarantee.

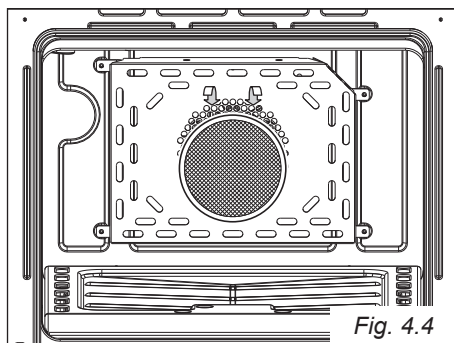

Fig. 4.4

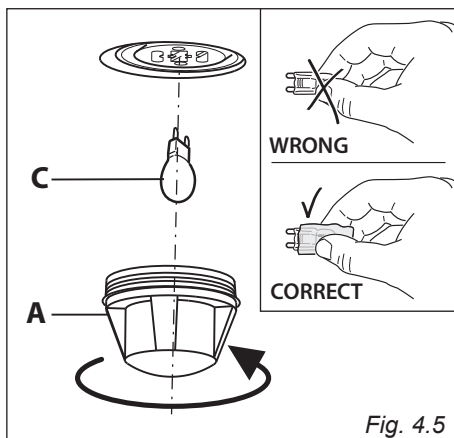
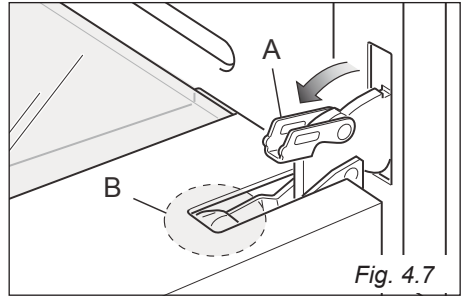
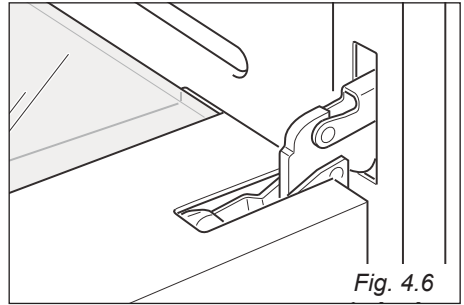

Fig. 4.5

## REMOVING THE OVEN DOOR

The oven door can easily be removed as follows:

- Open the door to the full extent (fig. 4.6).
- Open the lever “A” completely on the left and right hinges (fig. 4.7).
- Hold the door as shown in fig. 4.9.
- Gently close the door (fig. 4.8) until left and right hinge levers “A” are hooked to part “B” of the door (fig. 4.7).
- Withdraw the hinge hooks from their location following arrow “C” (fig. 4.10).
- Rest the door on a soft surface.



### Important!

Always keep a safe distance from the door hinges, paying special attention to position of your hands.

If the door hinges are not correctly hooked, they could unhook and close suddenly and unexpectedly with risk of injury.

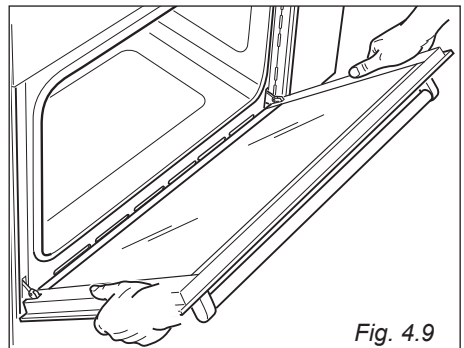
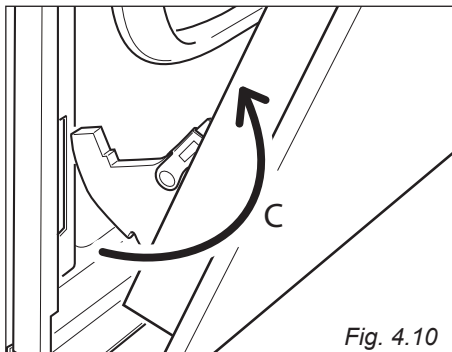
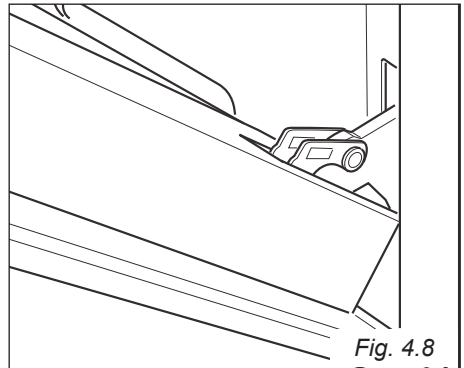
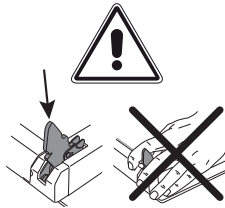

## REFIT THE DOOR

- Hold the door firmly (fig. 4.11).
- Insert the hinge tongues into the slots, making sure that the groove drops into place as shown in the fig. 4.12.
- Open the door to its full extent.
- Fully close the levers “A” on the left and right hinges, as shown in the figure fig. 4.13.
- Close the door and check that it is properly in place.

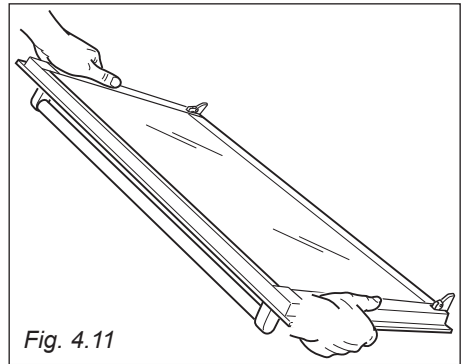

## REMOVING AND REPLACING THE INNER DOOR GLASS PANE FOR CLEANING (only for the models with removable inner pane of glass)

If you wish to clean the inner glass of the door, make sure you follow the precautions and instructions very carefully. Replacing the glass pane and the door incorrectly may result in damage to the oven and may void your warranty.

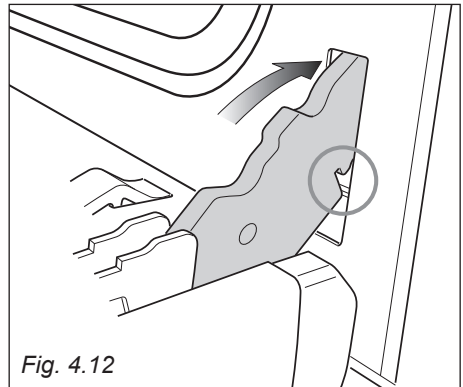

### IMPORTANT!

- Take care, the oven door is heavy. If you have any doubts, do not attempt to remove the door.
- Make sure the oven and all its parts have cooled down. Do not attempt to handle the parts of a hot oven.
- Take extreme care when handling the glass pane. Avoid the edges of the glass bumping against any surface. This may result in the glass shattering.
- Do not use harsh abrasive cleaners or sharp metal scrapers to clean the oven door glass since they can scratch the surface, which may result in shattering of the glass.
- If you notice any sign of damage on any of the glass panes (such as chipping, or cracks), do not use the oven. Call your Authorised Service Centre or Customer Care.
- Make sure you replace the glass pane correctly. Do not use the oven without glass pane correctly in place.
- If the glass pane feels difficult to remove or replace, do not force it. Call your Authorised Repairer or Customer Care for help.

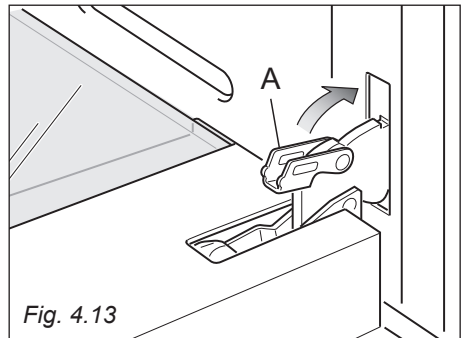

**Note:** Service visits providing assistance with using or maintaining the oven are not covered by your warranty.

## REMOVING THE INNER PANE OF GLASS (only for the models with removable inner pane of glass)

The oven door is fitted with no. 2 panes:

- no. 1 outside;
- no. 1 inner.

To clean all panes on both sides it is necessary to remove the inner pane as follows:

1. Lock the door open:
  - Open the door to the full extent (fig. 4.14).
  - Open the lever "A" completely on the left and right hinges (fig. 4.15).
  - Gently close the door (fig. 4.16) until left and right hinge levers "A" are hooked to part "B" of the door (fig. 4.15).
2. Remove the inner pane:
  - Gently pull out the inner pane of glass (fig. 4.17).
  - Clean the glass with an appropriate cleaner. Dry thoroughly, and place on a soft surface.

Now you can also clean the inside of the outer glass.

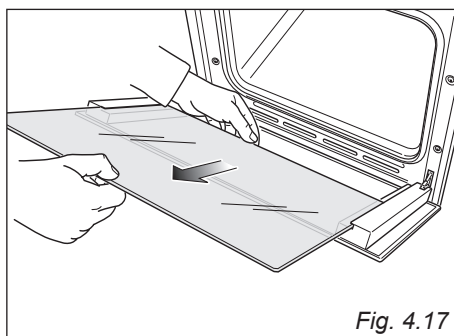
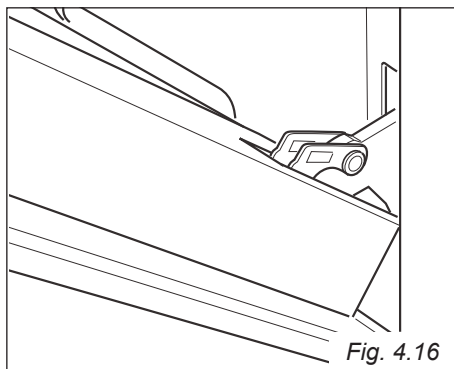
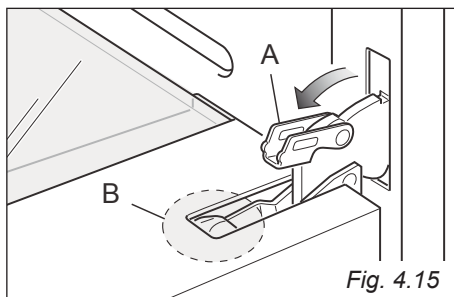
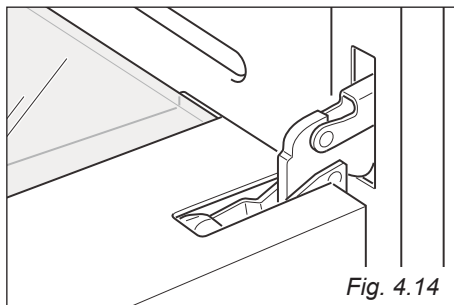

## AFTER CLEANING, REPLACE THE INNER GLASS PANE (only for the models with removable inner pane of glass)

When replacing the inner glass pane, make sure that:

- You replace the pane correctly, as shown. The pane must be in the position described below in order to fit into the door and to ensure that the oven operates safely and correctly.
- You take extra care not to bump the edges of the glass against any object or surface.
- You do not force the pane into place. If you are experiencing difficulties replacing the pane, remove it and start the process again from the beginning. If this still does not help, call Customer Care.

To reassemble the inner pane of the oven door operate as follows:

1. Make sure the door is locked open (see fig. 4.16).
  2. Replace the inner pane:
    - Check that the four rubber pads are in place (“D” in fig. 4.18).
- IMPORTANT:** It is advisable, while refitting the glass, to keep pressed in position the four rubber pads “D”, by a finger, to avoid breakage or slippage of the rubber pads themselves (fig. 4.19).
- Check that you are holding the pane the correct way. You should be able to read the wording on it as it faces you.
  - Insert the pane in the left “E” and right “F” slide guides (fig. 4.19), and gently slide it to the retainers “H” (fig. 4.20).
  - Unlock the oven door by opening it completely and closing the lever “A” on the left and right hinges (fig. 4.21).

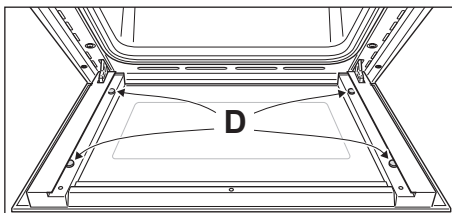

Fig. 4.18

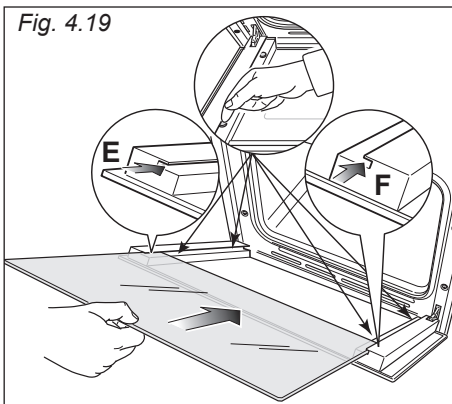

Fig. 4.19

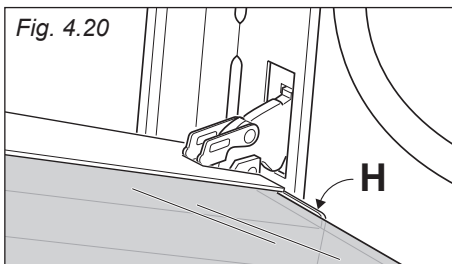

Fig. 4.20

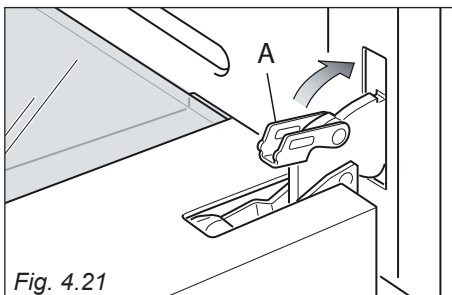

Fig. 4.21

## **DO'S AND DO NOT'S**

- Do always grill with the oven door closed.
- Do read the user instructions carefully before using the oven for the first time.
- Do allow the oven to heat for about two hours, before using for the first time, in order to burn off any protective oils.
- Do clean your oven regularly.
- Do remove spills as soon as they occur.
- Do always use oven gloves when removing food shelves and trays from the oven.
- Do not allow children near the oven when in use.
- Do not allow fat or oils to build up in the oven trays, grill pan or oven base.
- Do not place cooking utensils or plates directly onto the oven base.
- Do not grill food containing fat without using the grid.
- Do not cover the grilling grid with aluminium-foil.
- Do not use the oven tray for roasting.
- Do not clean the oven without first turning off the electricity supply and allow to cool.
- Do not place hot enamel parts in water. Leave them to cool first.
- Do not allow vinegar, coffee, milk, saltwater, lemon or tomato juice to remain in contact with enamel parts.
- Do not use abrasive cleaners or powders that will scratch the surface of the enamel.
- Do not attempt to repair the internal workings of your oven.
- Do not line the oven walls with aluminium foil. Do not place baking trays or the drip tray on the base of the oven chamber.

## **FOR YOUR SAFETY**

The product should only be used for its intended purpose which is for the cooking of domestic foodstuffs.

Under no circumstances should any external covers be removed for servicing or maintenance except by suitably qualified personnel.

---

***ADVICE***  
***for the***  
***INSTALLER***

---

# 5

## INSTALLATION

### IMPORTANT

- The appliance shall be installed, regulated and adapted to function only by a SUITABLY QUALIFIED TECHNICIAN.  
Failure to comply with this condition will render the guarantee invalid.
- The gas/electrical connection must be executed by a qualified technician in compliance with the regulations in force in your country and in observation of the manufacturer's instructions.
- Always disconnect the appliance from the electrical supply before carrying out any maintenance operations or repairs.
- Some appliances are supplied with a protective film on steel and aluminium parts.  
**This film must be removed before using the appliance.**
- The oven can be fitted in standard cabinets of 60 cm width and depth.
- Installation requires a compartment as illustrated in Figures 5.1a and 5.1b.
- On the lower side, the oven must lay on supports standing the oven weight.

**The appliance must be housed in heat resistant cabinets.**

**The walls of the cabinets must be capable of resisting temperatures of 75 °C above room temperature.**

**Do not instal the appliance near inflammable materials (eg. curtains).**

**Caution: Do not lift this oven by the door handle**

### WARNING

**When correctly installed, your product meets all safety requirements laid down for this type of product category.**

**However special care should be taken around the rear or the underneath of the appliance as these areas are not designed orintended to be touched and may contain sharp or rough edges, that may cause injury.**

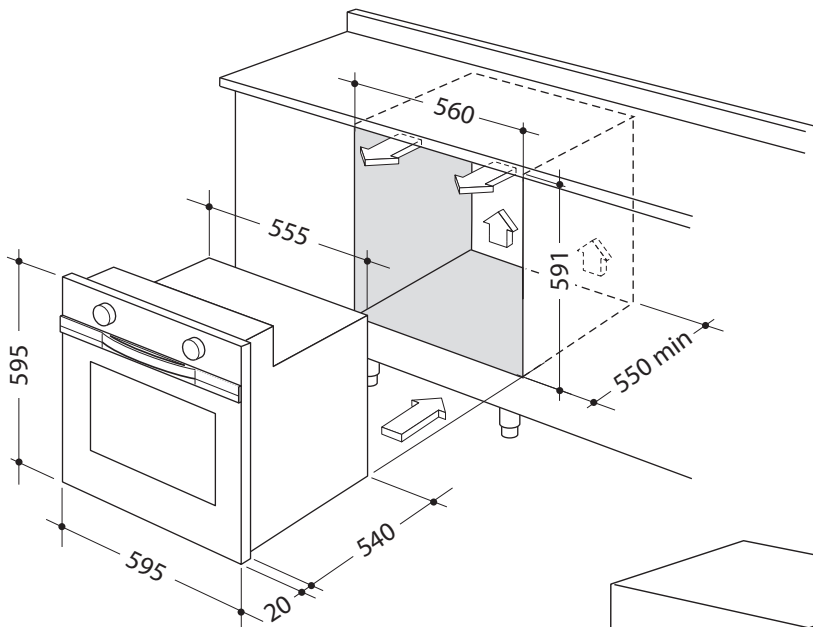

Fig. 5.1a

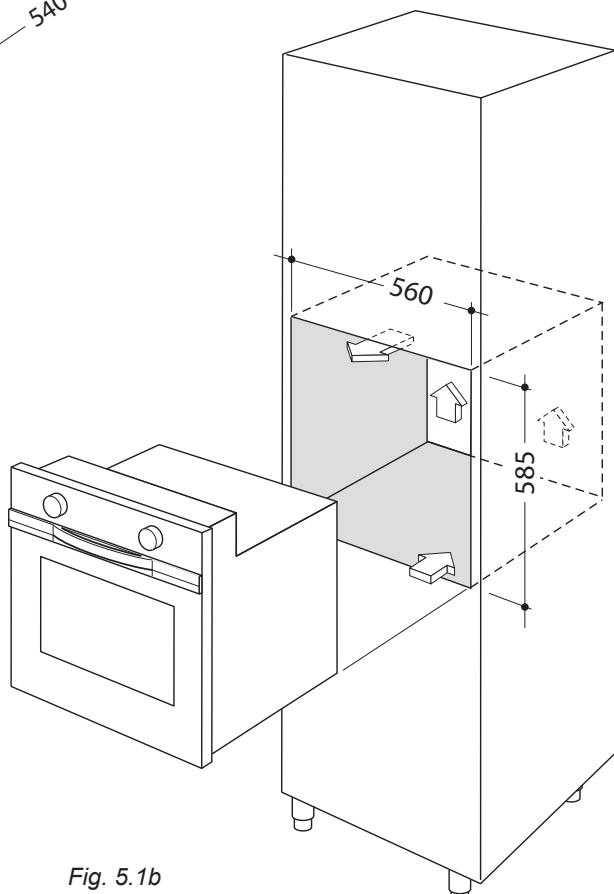

Fig. 5.1b

## FIXING THE OVEN

Introduce the oven into the furniture opening and fix it with 4 screws (not supplied) as figure 5.2. It is essential that the oven rests on a surface which will support its weight, as the screw fixing is only complementary. Adjust the hinges of furniture doors adjacent to the oven to allow a 4-5 mm gap between the furniture door and the oven frame.

### IMPORTANT:

**To avoid damage to the lower trim please note the following instructions.**

The lower trim is designed to allow for good air circulation and the correct opening of the oven door.

To ensure the trim is not damaged due to the appliance being placed on the floor, the appliance should be suitably supported as illustration here below.

After installation the appliance door should be slowly opened to ensure no damage has occurred.

**No responsibility for lower trim damage will be accepted if these instructions have not been followed.**

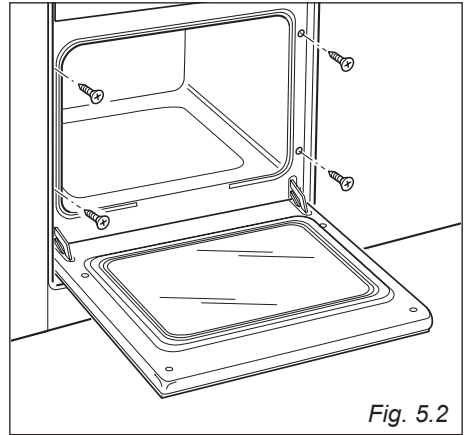

Fig. 5.2

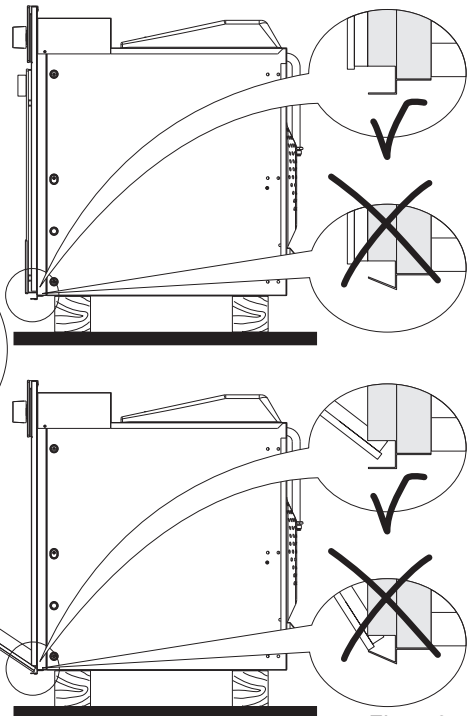
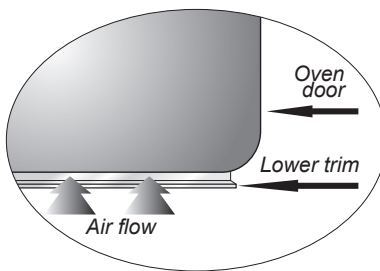

Fig. 5.3

## VENTILATION REQUIREMENTS

The appliance must be installed in compliance with applicable local regulations concerning ventilation and the evacuation of exhaust gases.

Intensive and prolonged use may require extra ventilation, e.g. opening a window, or more efficient ventilation increasing the mechanical suction power if this is fitted.

## CHOOSING SUITABLE SURROUNDINGS

The room where the gas appliance is to be installed must have a natural flow of air so that the gas can burn (in compliance with applicable local regulations).

The flow of air must come directly from one or more openings made in the outside walls with a free area of at least 100 cm<sup>2</sup> (or refer to applicable local regulations).

The openings should be near the floor and preferably on the side opposite the exhaust for combustion products and must be so made that they cannot be blocked from either the outside or the outside.

When these openings cannot be made, the necessary air can come from an adjacent room which is ventilated as required, as long as it is not a bed room or a danger area (in compliance with applicable local regulations).

In this case, the kitchen door must allow the passage of the air.

## DISCHARGING PRODUCTS OF COMBUSTION

Extractor hoods connected directly to the outside must be provided, to allow the products of combustion of the gas appliance to be discharged (fig. 5.4).

If this is not possible, an electric fan may be used, attached to the external wall or the window; the fan should have a capacity to circulate air at an hourly rate of 3-5 times the total volume of the kitchen (fig. 5.5).

The fan can only be installed if the room has suitable vents to allow air to enter, as described under the heading “Choosing suitable surroundings”.

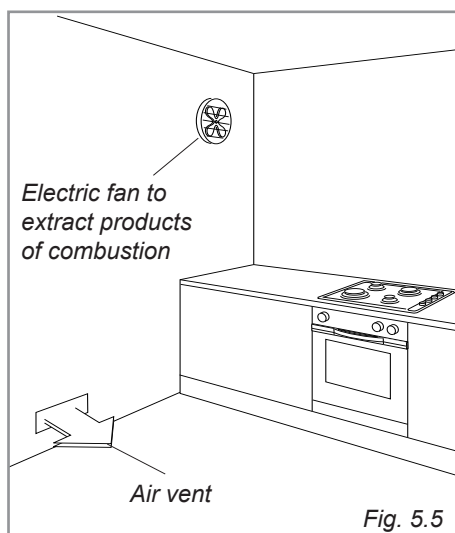
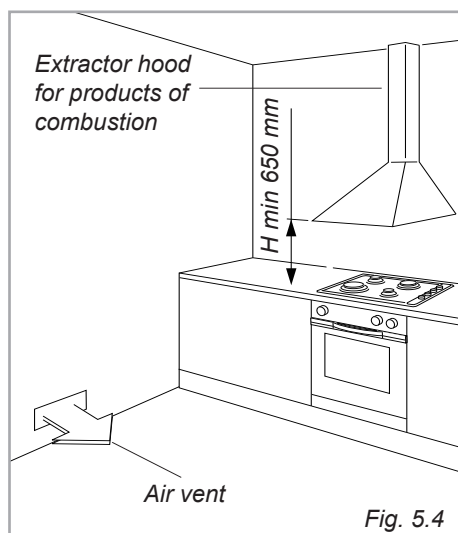

# 6

## GAS SECTION

### GAS INSTALLATION REQUIREMENTS

#### Important !

- **Before installation, make sure that the local distribution conditions (gas type and pressure) and the adjustment of this appliance are compatible. The appliance adjustment conditions are given on the plate or the label.**
- **This appliance must be installed and serviced only by a suitably qualified, registered installer with technical knowledge of both gas installation and electricity. The installation or service must comply with the current editions of the applicable standards, regulations, and codes of practice governing gas and electrical installations.**
- **Failure to install the appliance correctly could invalidate any manufacturer's warranty.**

This appliance is supplied for use on LPG (Cat. I 3+, G30/G31 28-30/37 mbar; check the gas regulation label attached on the appliance).

OR

This appliance is supplied for use on NATURAL GAS or LPG (Cat. II 2H 3+, G20 20 mbar, G30/G31 28-30/37 mbar; check the gas regulation label attached on the appliance).

- Appliances supplied for use on NATURAL GAS: they are adjusted for this gas only and cannot be used on any other gas (LPG) without modification. The appliances are manufactured for conversion to LPG.
- Appliances supplied for use on LPG: they are adjusted for this gas only and cannot be used on any other gas (NATURAL GAS) without modification. The appliances are manufactured for conversion to NATURAL GAS.

If the NATURAL GAS/LPG conversion kit is not supplied with the appliance this kit can be purchased by contacting the After-Sales Service.

## CONNECTING TO THE GAS SUPPLY

The gas connection fitting (Fig. 6.2) is made up of:

- the floating nut;
- the gasket.

**The gas connection must be carried out by an authorised person according to the relevant local standards.**

- If using a flexible hose, make sure it does not come into contact with moving parts.
- The supplied gasket guarantees a good seal for the gas connection. We recommend that you replace the gasket on the slightest sign of wear, deformation or imperfection.
- **After connecting to the gas mains, check that the couplings are correctly sealed, using soapy solution, but never a naked flame.**

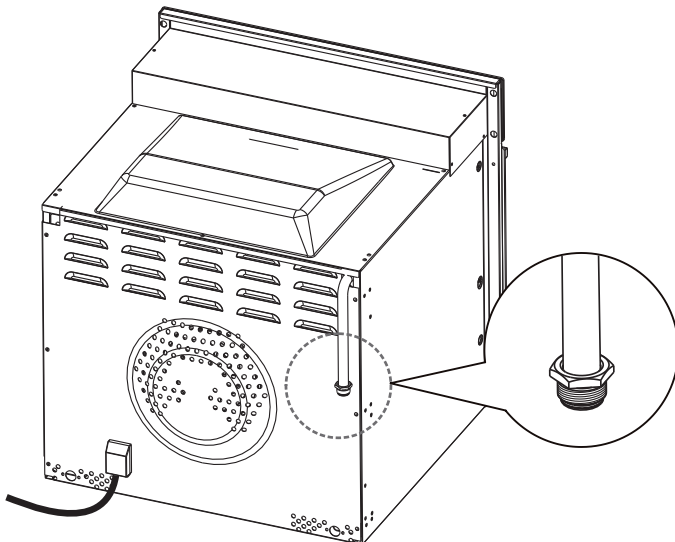
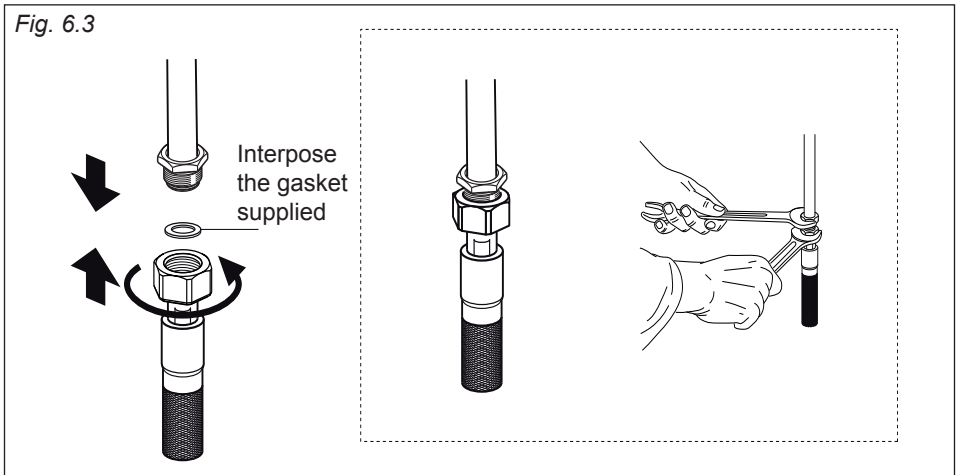
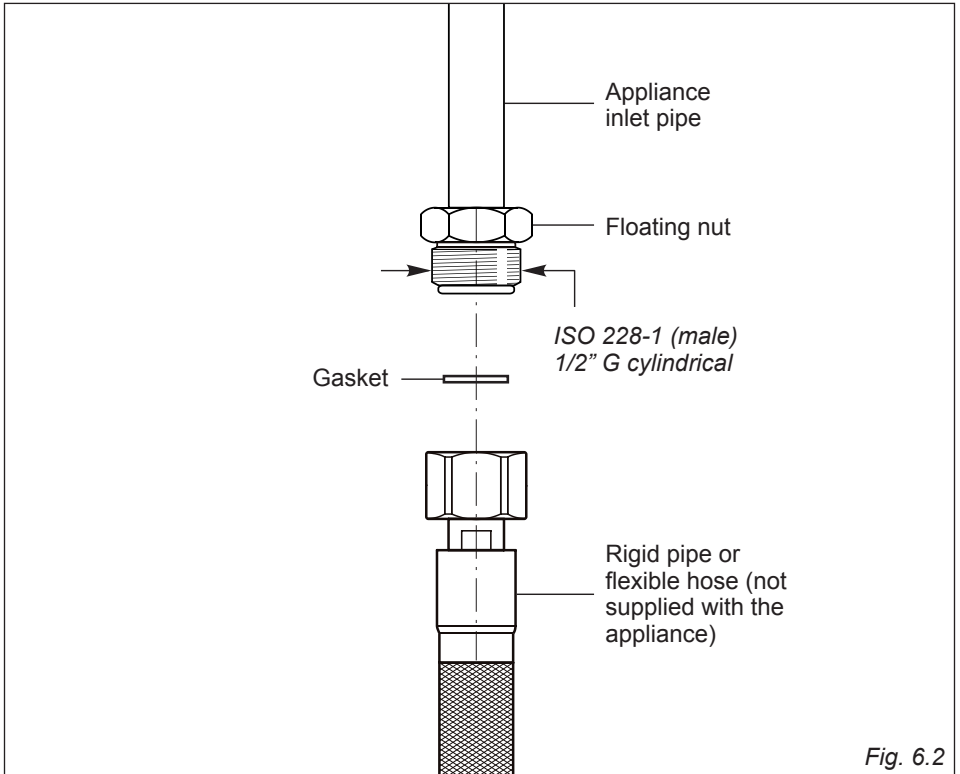

Fig. 6.1

## DETAILS FOR CONNECTING TO THE GAS SUPPLY

The components described in fig. 6.2 shall be fixed as indicated in fig. 6.3.



## **ADDITIONAL GAS CONNECTION REQUIREMENTS**

When connecting the appliance to the gas supply with rigid pipes or a flexible hose, make sure that:

- You use rigid pipes or a flexible hose compliant with applicable local regulations. The flexible hose shall be of the correct construction for the type of gas being used and of the correct size to maintain the heat output of the appliance.
- The connection with rigid metal pipes does not cause stress or pressure to the gas piping.
- The flexible hose is not under tension, twisted, kinked, or too tightly bent, neither while the appliance is in use nor while it is being connected or disconnected.
- The flexible hose is not longer than 2000 mm (or refer to applicable local regulations) and does not come into contact with sharp edges, corners, or moving parts, as these may cause abrasion. Use a single flexible hose only; never connect the appliance with more than one flexible hose.
- The flexible hose can easily be inspected along its entire length to check its condition; if it has an expiry date, it should be replaced before that date.
- If using a flexible hose which is not entirely made of metal, make sure that it does not come into contact with any part of the appliance with a surface temperature of 70°C or above (or refer to applicable local regulations).
- The rigid pipe or flexible hose is replaced if it shows signs of damage.
- The flexible hose is not subject to excessive heat by direct exposure to flue products or by contact with hot surfaces.
- The socket into which the plug of the flexible hose fit is permanently attached to a firmly fixed gas installation pipe and is positioned so that the hose hangs freely downwards.
- The plug of the flexible hose is accessible after installation, so that it can be disconnected for service or removal.
- You inform the customer that the rigid pipe or flexible hose should not be subjected to corrosion by cleaning agents.

# GAS MAINTENANCE

Some models - for the gas category check the data label attached on the appliance

<b>TABLE FOR THE CHOICE OF THE INJECTORS - Cat: I 3+</b>				
BURNERS	Nominal power [kW]	Reduced power [kW]	LPG	
			G30 (28-30 mbar) G31 (37 mbar)	
			Ø injector [1/100 mm]	Ring opening [mm]
Oven	2,70	0,65	78	Fully open (*)
Grill	1,70	-	68	4 (*)

(\*) = Reference value

Some models - for the gas category check the data label attached on the appliance

<b>TABLE FOR THE CHOICE OF THE INJECTORS - Cat: II 2H 3+</b>						
BURNERS	Nominal power [kW]	Reduced power [kW]	LPG		Natural gas	
			G30 (28-30 mbar) G31 (37 mbar)		G20 (20 mbar)	
			Ø injector [1/100 mm]	Ring opening [mm]	Ø injector [1/100 mm]	Ring opening [mm]
Oven	2,70	0,65	78	Fully open (*)	120	2 (*)
Grill	1,70	-	68	4 (*)	105	2 (*)

(\*) = Reference value

<b>AIR VENT NECESSARY FOR GAS COMBUSTION = (2 m<sup>3</sup>/h x kW)</b>	
BURNERS	Air necessary for combustion [m <sup>3</sup> /h]
Oven	5,40
Grill	3,40

## IMPORTANT

**All intervention regarding installation and maintenance of the appliance must be fulfilled with original factory parts.**

**The manufacturer declines any liability resulting from the non-compliance of this obligation.**

## OPERATIONS TO BE EXECUTED FOR THE REPLACEMENT OF THE INJECTORS OF THE OVEN AND GRILL BURNERS

Some models are provided with a set of injectors for the various types of gas.

**If the injectors are not supplied they can be obtained from the “Service Centre”.**

Select the injectors to be replaced according to the “Table for the choice of the injectors” (for the gas category check the data label attached on the appliance).

The nozzle diameters, expressed in hundredths of a millimetre, are marked on the body of each injector.

### OVEN BURNER

- Lift and remove the lower panel inside the oven.
- Unscrew and remove the burner securing screw “A” (fig. 6.4a).
- Withdraw the burner as shown in figure 6.4b and rest it inside the oven. Take care not to damage the safety valve probe and the electric ignition electrode.
- Using a 7 mm box spanner, unscrew the injector (indicated by the arrow in fig. 6.4b) and replace it with a new one selected in accordance with the “Table for the choice of the injectors”.
- Regulate the air supply to the oven burner as indicated in the section “REGULATION OF AIR SUPPLY TO OVEN AND GRILL BURNERS”; then replace the burner repeating the above steps in reverse order.

**IMPORTANT: Check the correct operation of the safety valve and the electric ignition.**

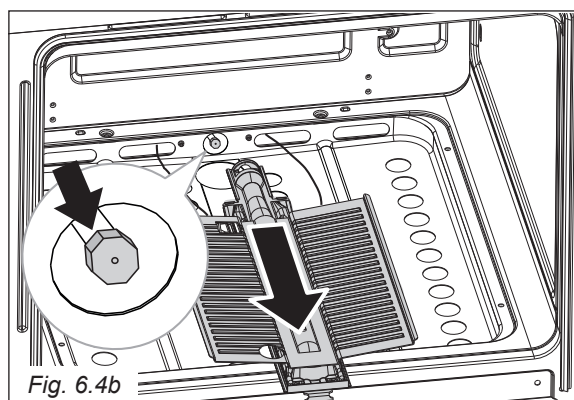
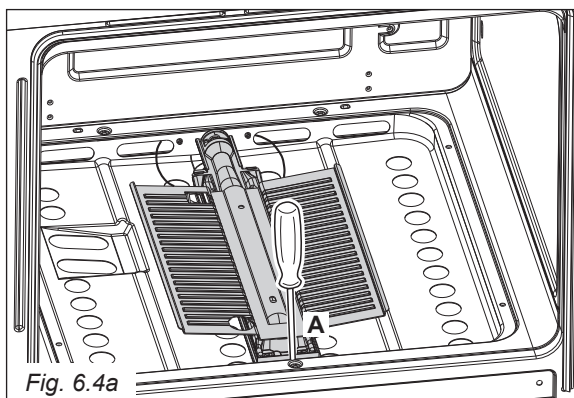

## GRILL BURNER

- Unscrew and remove the burner securing screw “A” (fig. 6.5a).
- Withdraw the burner as shown in figure 6.5b. Take care not to damage the safety valve probe and the electric ignition electrode.
- Using a 7 mm box spanner, unscrew the injector (indicated by the arrow in fig. 6.5b) and replace it with a new one selected in accordance with the “Table for the choice of the injectors”.
- Regulate the air supply to the grill burner as indicated in the section “REGULATION OF AIR SUPPLY TO OVEN AND GRILL BURNERS”; then replace the burner repeating the above steps in reverse order.

**IMPORTANT: Check the correct operation of the safety valve and the electric ignition.**

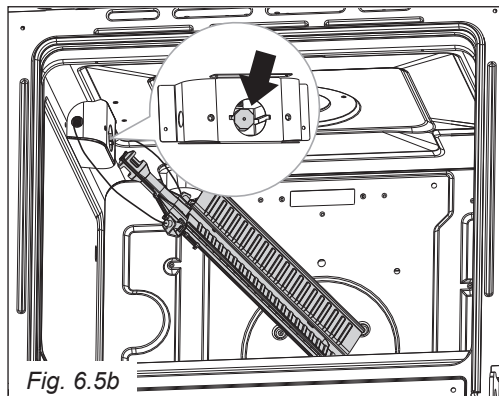
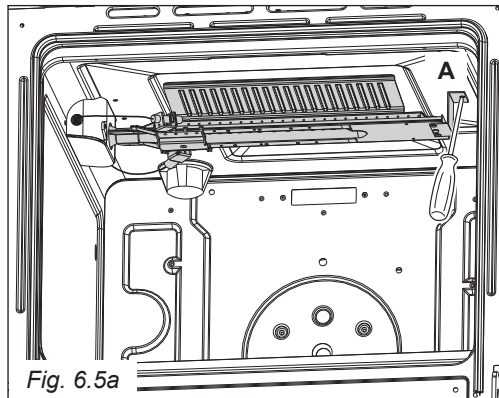

## REGULATION OF AIR SUPPLY TO OVEN AND GRILL BURNERS

To regulate the air supply it is necessary to remove the burners from their housings (figs. 6.4b - 6.5b).

- Using a cross-head screwdriver, slacken the screws “A” securing the air flow regulation collar “B” (fig. 6.6) and move the collar forward or backward to increase or reduce the air aperture in accordance with gas type and the indications in the “Table for the choice of the injectors”.

**IMPORTANT:** If the air flow regulation collar “B” is not already fitted on the burner (e.g. oven burner set in the factory for LPG use), it is supplied with the kit for the gas conversion. In this case the air flow regulation collar “B” shall be fitted as indicated in figure 6.6:

- the collar “B” shall be folded around the burner (one half part at the top and one half part at the bottom);
  - the throttled section shall be oriented toward the burner deflector (opposite side with respect to the injector).
- Replace and light the burners to check the flames.

Fig. 6.6

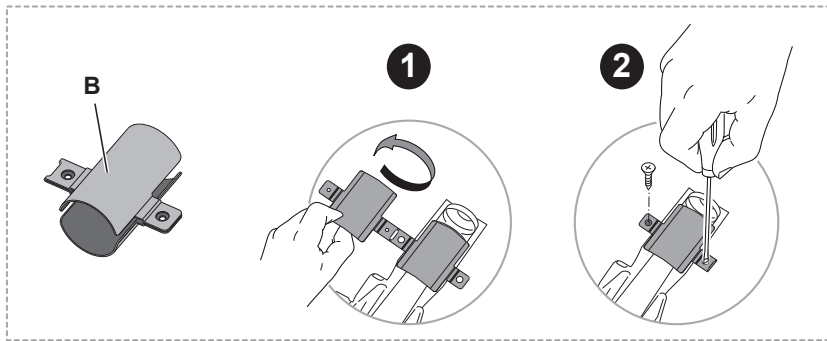
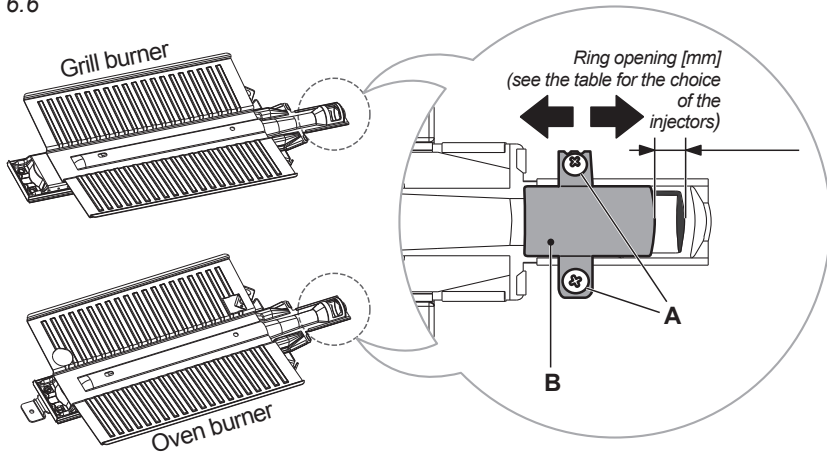

Flame faulty in primary air	Flame correct	Flame with excess primary air
<i>flong, yellow and trembling</i>	<i>clear interior blue cone</i>	<i>short and sharp too blue interior cone tending to detach</i>
<b>CAUSE</b>		
<i>air regulating tube, too closed</i>	<i>correct distance of the tube</i>	<i>air regulating tube, too open</i>



Flame correct



Flame faulty in primary air



Flame with excess primary air

## ADJUSTMENT OF THE OVEN BURNER MINIMUM

This needs to be done only for the oven burner (the grill is a fixed capacity) by acting on the thermostat.

In the minimum position the flame must have a length of about 4 mm and must remain lit even with a brusque passage from the maximum position to that of minimum.

The flame adjustment is done in the following way:

- Turn on the oven burner by setting the thermostat knob on maximum position (“10” or “240”).
- Remove the knob and unscrew the by-pass screw “G” (fig. 6.7) about three times by passing a small flat screwdriver (Ø 3 mm blade, 100 mm length) through the control panel opening.  
Note: for the models with glass control panel, for easy access to the by-pass screw, it is suggested to remove control panel itself (fig. 6.8). To do that unscrew the two screws on the bottom side of the control panel and then move, toward the outside, the bottom edge of the glass until the complete extraction of the bottom fixing tongues. Then let it slide downwards to disengage the top fixing tongues.
- Remount the knob and let the oven heat up for about 15 minutes, then bring the knob to the minimum position (“1” or “130”) to operate the thermostat by-pass.
- After having removed the knob again and being very careful not to turn the thermostat rod, slowly screw the by-pass screws “G” (fig. 6.7) until you obtain a flame of 3-4 mm in height.
- Turn off the burner and reassemble the knob.

**N.B. For G30/G31 (LPG) the by-pass screw must be fixed thoroughly.**

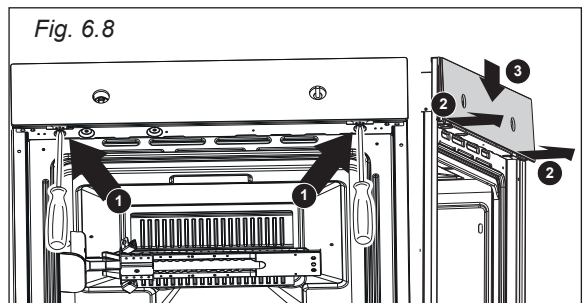
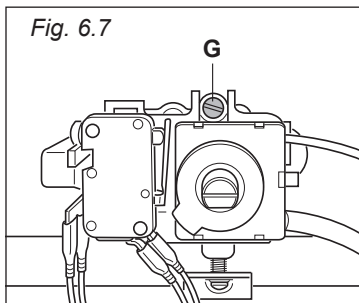

**Before effecting any intervention on the electrical parts the appliance must be disconnected from the network.**

## GENERAL

- The connection to the electrical network must be carried out by qualified personnel and must be according to existing norms.
- The appliance must be connected to the electrical network verifying above all that the voltage corresponds to the value indicated on the specifications plate and that the cables section of the electrical plant can bear the load which is also indicated on the plate.
- If the appliance is supplied without a power supply plug and if you are not connecting directly to the mains, a standardized plug suitable for the load must be fitted.
- The colours of the wires in the appliance power cable may not correspond with the colours marked on the terminals of your electrical plug/ fuse spur outlet. For the connection proceed as follows:
  - The wire which is coloured green and yellow must be connected to the terminal which is marked with letter **E** or by the  $\perp$  (Earth) symbol or coloured green and yellow.
  - The wire which is coloured blue must be connected to the terminal which is marked with the letter **N** (Neutral) or coloured black.
  - The wire which is coloured brown must be connected to the terminal which is marked with letter **L** (Live) or coloured red.
- The bi-polar plug must be connected to an outlet connected to the grounding unit in conformity to security norms.
- If the oven is to be connected directly to the mains, it must be placed with an omnipolar switch with minimum opening between the contacts of 3 mm between the appliance and the mains.
- The power supply cable must not touch the hot parts and must be positioned so that it does not exceed 75°C at any point.
- Once the oven has been installed, the switch or socket must always be accessible.
- If the power supply cable is damaged it must be substituted by a suitable cable available in the after sales service.

**N.B. For connection to the mains, do not use adapters, reducers or branching devices as they can cause overheating and burning.**

If the installation requires alterations to the domestic electrical system call an expert. He should also check that the domestic electrical system is suitable for the power absorbed by the appliance.

**The connection of the appliance to the grounding unit is mandatory. The manufacturer declines every responsibility for any inconvenience resulting from the inobservance of this condition.**

## CONNECTION OF THE POWER SUPPLY CABLE

**WARNING:** If the power supply cable is damaged, it must be replaced only by an authorised service agent in order to avoid a hazard.

- Unhook the terminal board cover by inserting a screwdriver into the two hooks "A" (fig. 7.1).
- Open the cable gland by unscrewing screw "F" (fig. 7.2), unscrew the terminal screws and remove the cable.
- The new supply cable, of suitable type and section, is connected to the terminal board following the diagram of fig. 7.3.

**N.B.** The earth conductor must be left about 3 cm longer than the others.

The operations must be executed by a qualified technician.

### FEEDER CABLE SECTION

**TYPE "H05RR-F" or "H05V2V2-F" resistant to temperatures of 90°C**

220-240 V ac    3 x 0,75 mm<sup>2</sup>

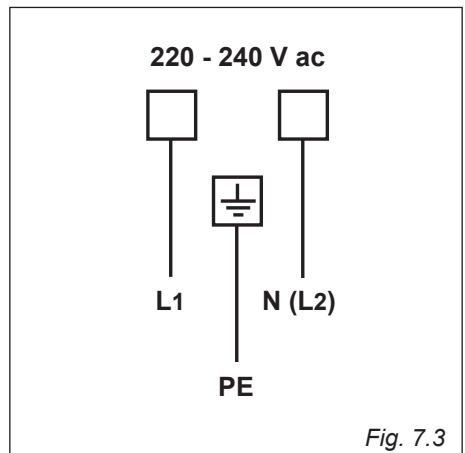
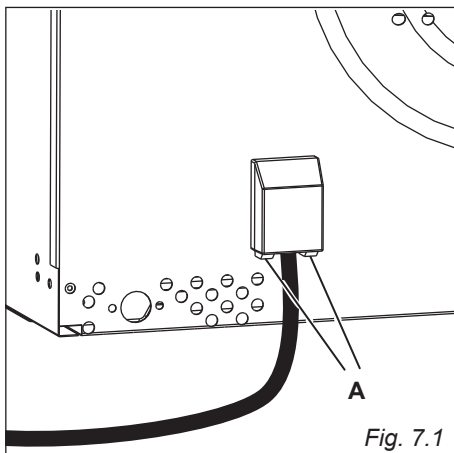
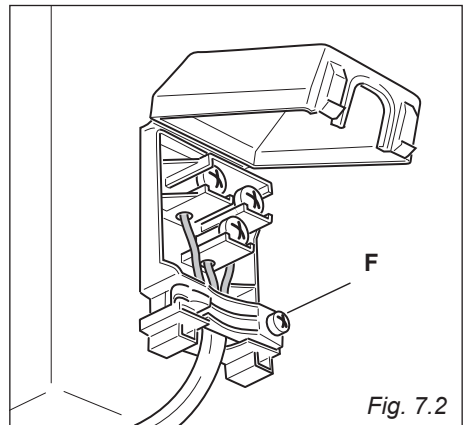





The manufacturer cannot be held responsible for possible inaccuracies due to printing or transcription errors in the present booklet.

The manufacturer reserves the right to make all modifications to its products deemed necessary for manufacture or commercial reasons at any moment and without prior notice, without jeopardising the essential functional and safety characteristics of the appliances.